

# Heavy-duty checkweigher for large cases, barrels, bags and boxes

## Thermo Scientific Versa Flex FR44HD Heavy-duty Checkweigher

The Thermo Scientific™ Versa Flex Frame 44HD checkweigher offers dependable and accurate on-line weighing of large packages maximizing productivity and profitability.

### Features include:

- Dependable and accurate on-line weighing of packages up to 100 lbs. (250 lbs. for XD)
- Ideally suited for rugged industrial environments
- Line rates up to 100 packages per minute - up to 560 fpm depending on package length
- Tough and sturdy stainless construction for heavier and larger products
- Available in extended sizes (XD)
- Conversion kit for upgrade available

### State-of-the-art Electronics

The Versa Flex Frame 44HD checkweigher offers the highest accuracy at the fastest speed and is designed to eliminate the learning curve. The Versa Flex control comes standard with Linux and features an easy-to-operate global platform with multi-language capability.



### Controller Upgrade on Existing Frames

If your existing weigh conveyor Frame 44HB weigh conveyor (formerly sold under the Ramsey brand name) is in good condition and you are interested in expanding its life, we provide a Versa Flex Conversion Kit to replace your present controller.

### Customized Options

Engineered for true in-motion weighing of a wide variety of package weights without stopping the conveyor or needing to recalibrate. This flexibility guarantees that you'll experience maximum productivity at all times. The Versa Flex Frame 44HD checkweigher can be configured with an FDA-approved food-grade belt – making it the ideal choice for transferring raw or frozen products in bags, cases, boxes or barrels.

## Thermo Scientific Versa Flex Frame 44HD checkweigher

Specifications	
Weigh Range	Up to 100 lbs (HD Series). Extended size XD versions available up to 250 lbs
Speed	33-560fpm (10 to 164 mpm) on HD and XD systems
Operating Temperature	+40°F to +105°F (5°C to +40°C)
Package Length	Up to 45 in. (1143 mm) HD (XD to 70")
Package Pitch (spacing)	Weightable length plus 1 in. (25.4 mm) or more (See B dimensions in drawing)
Line Height	18 in. (457 mm) to 50 in. (1270 mm), 2 in. (51 mm) increments with a ±2 in. (±51 mm) adjustment. XD 24 in. minimum ±2 in.
Frame Construction	Stainless steel
Conveying Media	Belt – FDA-approved blue belting or black waffletop belting
Weight Sensing System	Four (4) strain gauge loadcells
Photo Eye	Emitter/receiver photo eye arrangement
Power	Single Drop 115-230VAC 60 Hz 1 Phase. Control power consumption, 300 VA.
Harsh Washdown Environment Option	IP 65 includes washdown motor and environmentally sealed loadcells, bearings (see washdown option)
Compatible Controls	Thermo Scientific Versa Flex controller

## Thermo Scientific Versa Flex Frame 44HD checkweigher physical dimensions

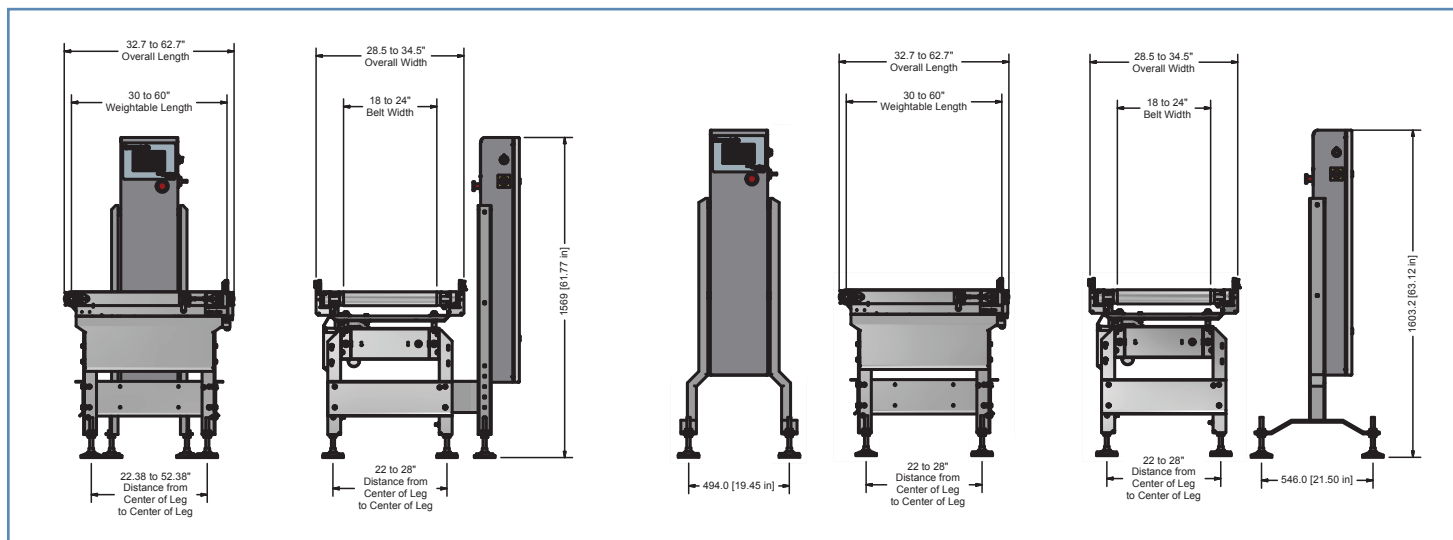

For more information [thermofisher.com/VersaFlexFR44HD](http://thermofisher.com/VersaFlexFR44HD)

**ThermoFisher**  
SCIENTIFIC