

# Thermo Scientific Versa Flex Checkweighers

## Specifications

Weighing Range	10g to 6kg
Line Speed	Models up to 3.0 kg (6.61 lb) capacity: Up to 95m/min (312 ft/min) Models over 3.0 kg (6.61 lb) capacity: Up to 90 m/min (295 ft/min) <i>Pack rates dependent upon package length and weigh table length.</i>
Product Rate	Up to 250 packages/min (depending on application)
Product Type	Any, including cartons, bags, cups, bottles, jars, pouches, boxes, etc.
Product Dimensions	Length: 25 mm to 500 mm. Maximum width 400 mm.
Accuracy	Random error: to OIML R51 International Standards. European MID Standards and Handbook – 44 U.S. standards or better. <i>Actual accuracy may differ depending upon package weight, speed, stability and roller type.</i>
Service Specifications	Electrical – 110/120 or 220/240 VAC, 50 or 60 HZ, single phase 15 A Max Air – Dry, 550-690 kPa, 5.5-6.9 bar (80-100 psi) » 1,000 l/min (35 CFM)* *Depending on application and configuration.
Overall Dimensions	Length: 750 mm to 2000 mm. Width: approx. 845 to 1500 mm depending on configuration.
Line Height	USA: 650 mm~1100 mm ±80 mm GP model: 630 mm~1150 mm ±50 mm
Approvals or Standards	CE Low-Voltage Directive 2006/95/CE CE Machinery Safety Directive 2006/42/CE CE Electro-Magnetic Compatibility Directive 2004/108/CE Complies with EC Directive 2002/95/EC
Ingress Protection	IP54
Material	Frame: 304 grade Stainless Steel (bead blast finish). Cabinet and conveyor beds (4b finish). Rollers: hard anodized aluminum or SST (option); load cell aluminum or SST (option) Belts: Urethane FDA Blue UU20 or FDA Blue E2/1~E3/1 type depending on conveyor dimensions and application
Pollution Degree	Pollution degree II
Weight Classification Zones	3 or 5 zone selectable.



**Thermo Scientific Versa Flex and Versa Flex GP Checkweighers**

- Versatile for Dry Applications
- High Accuracy and Stability
- Low Cost of Ownership

**Dimensional Diagram of Thermo Scientific™ Versa Flex**

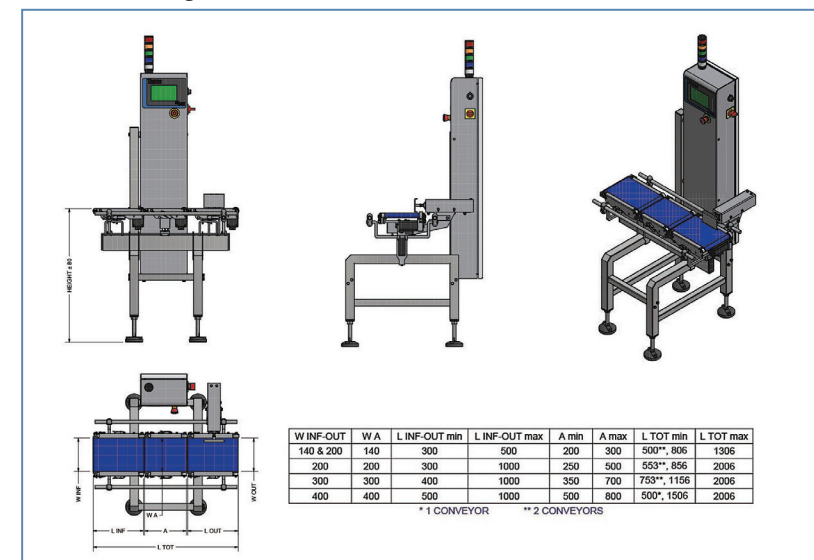

**Dimensional Diagram of Versa Flex GP**

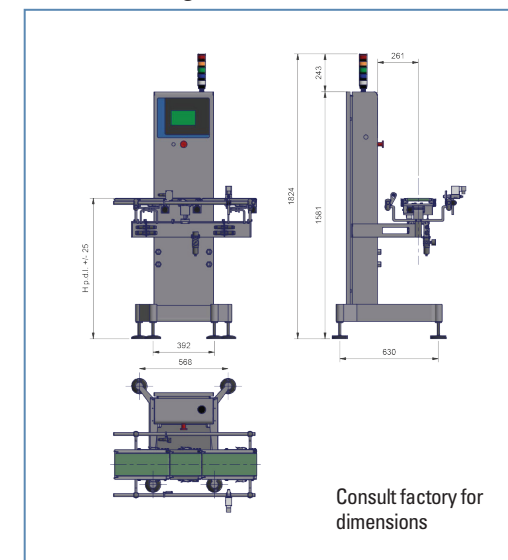

## Reliable general purpose checkweighing systems

Improve efficiency and profitability with checkweighers designed for dry applications. Enjoy high accuracy and advanced features with a standard system suitable for food, personal care or pharmaceutical applications.

[thermofisher.com/VersaFlex](http://thermofisher.com/VersaFlex)

© 2016 Thermo Fisher Scientific Inc. All rights reserved. All trademarks are the property of Thermo Fisher Scientific Inc. and its subsidiaries. Specifications, terms and pricing are subject to change. Not all products are available in all countries. Please consult your local sales representative for details.

**US and Canada** 800 227 8891  
**Australia/NZ** +1300 735 292  
**Mexico** +52 55 5639 2184  
**Argentina** +54 11 4334 3827  
**Chile** +56 22 2378 5080

**India** +91 20 6626 7000  
**Italy** +39 0 5217 8861  
**France** +33 (0) 16 092 4800  
**Germany** +49 (0) 20 882 4930  
**Spain** +34 (0) 91 484 5965

**UK** +44 (0) 17 8882 0300  
**Netherlands** +31 (0) 76 579 5555  
**South Africa** +27 11 776 0000  
**China** 800 810 5118  
**Brazil** +55 11 2730 3261  
**Southeast Asia** +65 6499 9981

**Thermo**  
SCIENTIFIC  
A Thermo Fisher Scientific Brand

**Thermo**  
SCIENTIFIC

# Thermo Scientific Versa Flex Checkweighers

versatile checkweighers to meet your needs

The Thermo Scientific™ Versa Flex and Versa Flex GP checkweighers are designed to improve accuracy and reliability, decreasing maintenance, product giveaway and total cost of ownership. Our global manufacturing and service teams enable a high level of solutions and service support wherever you do business.

Drawing from more than 50 years of experience in checkweigher application, design, and use, this newest member of the Versa checkweigher product line uses a new, feature-rich controller and configurable frame design to drive down total cost of ownership for dry package weighing applications.



The Versa Flex and Versa Flex GP are ideal for weighing a wide range of packaged food, pharmaceutical and personal care products in dry environments – from light to heavy-weight packages.



## Performance

The Versa Flex and Versa Flex GP meet or exceed a variety of regional and international standards. Proprietary software with advanced automatic-zero algorithms ensures accuracy standards are maintained over time, regardless of environment.

## Versatility and Ease of Use

- Easy-to-read color touch screens
- Configurable security access levels
- Intuitive menu operation
- Choice of 9 standard languages

Our proprietary 'Weigh Engine' uses the powerful Thermo Scientific™ AutoCalc™ signal processing system for ease of product set up. Modular electronic design allows easy repair if needed.



## Sanitary Design and Ease of Maintenance

- Frames designed to minimize flat surfaces and slots, reducing food buildup.
- Stainless steel conveyor beds
- Rapid-release conveyors and belts eliminate need for tools to remove or replace
- Tool-less thumb screw adjusts belt tracking
- Captive conveyor rollers easy to adjust

## Wide Range of Solutions

Building on a foundation of standard features, these checkweighers can be configured to create cost-effective solutions for the most challenging applications. A wide variety of product handling and reject hardware and software options are available.

All Versa Flex and Versa Flex GP checkweighers are offered with integrated infeed Thermo Scientific™ APEX metal detectors.

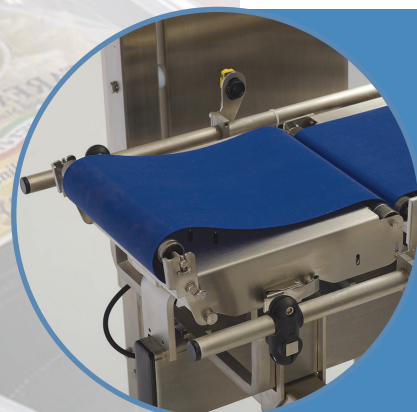

## Durability

High-torque sealed brushless motors allow trouble-free operation and long mean time between failures (MTBF).

## Service and Support

A wide range of service and support contracts cover factory acceptance testing, start up, and commissioning and validation.

