



Matrix is an industry leading manufacturer of rugged, cost competitive, and easy-to-operate vertical form fill & seal (VFFS) equipment for all types of flexible packaging and operates as a master distributor for INVpack offering stickpack and sachet machines, and Pacraft offering pre-made pouch packaging machines. Experienced in many flexible packaging applications, Matrix has the ability and knowledge to tailor highly efficient and sensible packaging systems and is committed to optimizing solutions for customers on a global scale. Matrix is a product brand of ProMach, a global leader in packaging line solutions. As part of the ProMach Flexibles & Trays business line, Matrix helps our packaging customers protect and grow the reputation and trust of their consumers. ProMach is performance, and the proof is in every package. Learn more about Matrix at www.MatrixPM.com and more about ProMach at www.ProMachBuilt.com.



Turnkey Packaging Solutions for the Canadian Manufacturing Industry

MD Packaging is part of the Tessera Group, and is a 100% Canadian company with regional offices in Toronto, Montreal, Calgary, Vancouver and Summerside PEI. As a truly full-service organization, MD Packaging provides Canadian representation for many of North America and Europe's premier OEMs like Matrix Packaging Machinery.

As experts in the packaging field, they work very closely with customers to provide turnkey solutions and high-level integration services during and after installation. With an in-house parts, service department, and factory-trained technicians, they help Canadians get the most out of their packaging lines.

Matrix

2395 Dakota Dr. • Grafton, WI 53024

P: 262-268-8300

TOLL FREE: 888-Matrix1

E: Matrix@ProMachBuilt.com

MatrixPM.com

MD Packaging

141 Reach St Unit 5A, Uxbridge, ON • L9P 1L3, Canada

P: +1 416-291-9229

E: info@mdpackaging.com

www.mdpackaging.com



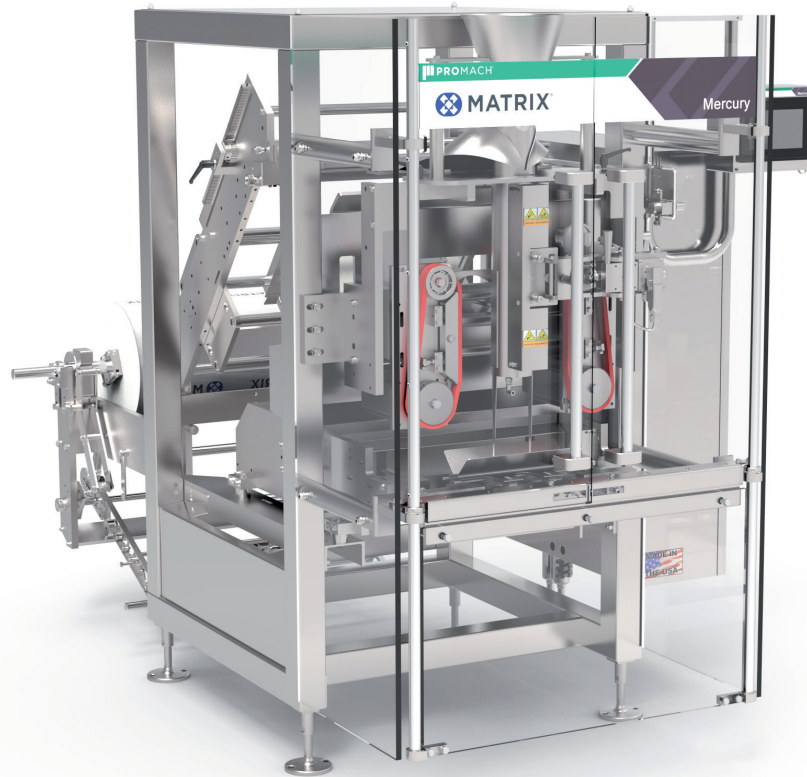

MERCURY

VERTICAL FORM/FILL/SEAL

F&T

FLEXIBLES
& TRAYS



MERCURY

VERTICAL FORM/FILL/SEAL

The Matrix Mercury Inspires Confidence with Reliable Repeatability in a Packaging Machine

The Matrix Mercury is the most popular Matrix form-fill-seal machine due to its speed, dependability, and low annual operating cost. Its capability to seal laminate or poly film along with a self-centering film drive down system, automatic edge guide film tracking, a short travel film unwind system, and angled incline film upwind, all contribute to precise film movement and trouble-free operation.

This machine is fully compatibility with all types of fillers and its tool-free quick-change core chucks help to ensure fast changeover between jobs.

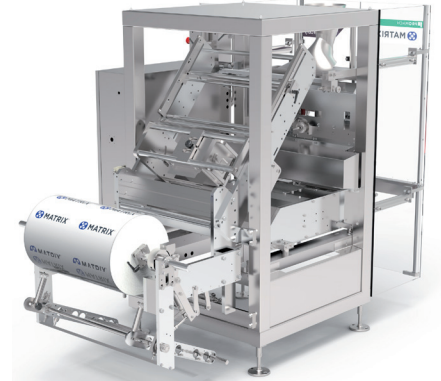

The Matrix Mercury offers exceptional speed, reliability and performance in an easy to use, automated packaging machine.

FEATURES & BENEFITS

- Made in the USA
- Stainless steel frame and NEMA 4X electrical enclosure with stainless steel adjustable mounting feet
- Allen Bradley MicroLogix PLC with 7" color touch screen
- Beckhoff servo motors for film pull and jaw motion control
- Compared to other high-speed machines, the Mercury has a small footprint, conserving valuable floor space
- Film length controlled by encoder feedback servo system
- Automatic film tracking, registered film photo eye and print registration roller
- Roller, and easy film splice
- Quick change T-slot jaw faces

OPTIONS

- Independent seal platens for poly film
- Mechanical or heated hole punch
- Tear notch
- Flat bottom bag and gusset/tucker attachment
- Digital gas flush
- Washdown with drip pan
- Load shelf
- Thermal transfer printer and encoder
- UL electrical system (built and certified in-house)
- Power unwind
- Ultra sonic edge guide sensor
- Vacuum belts

BAG STYLES



PILLOW BAG



GUSSET BAG



FLAT BOTTOM BAG



MODIFIED DOYPOUCH FILM WITH STAND-UP POUCH SYSTEM OPTION, (available with or without zipper)



CONFIGURATION

Top view

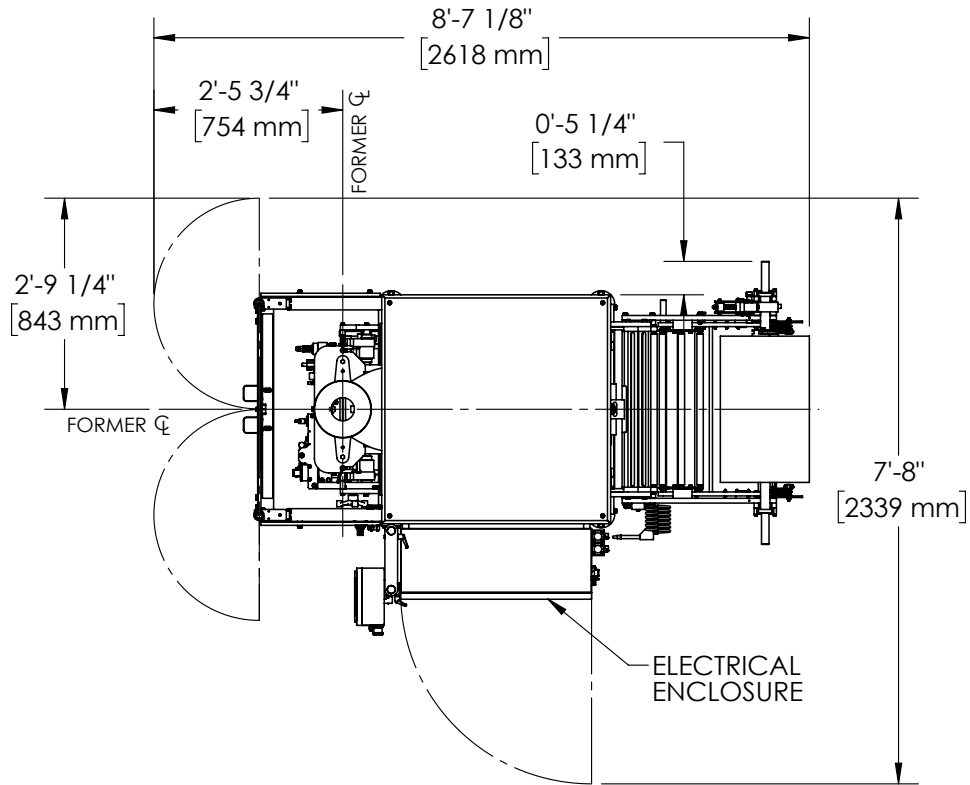

Front view

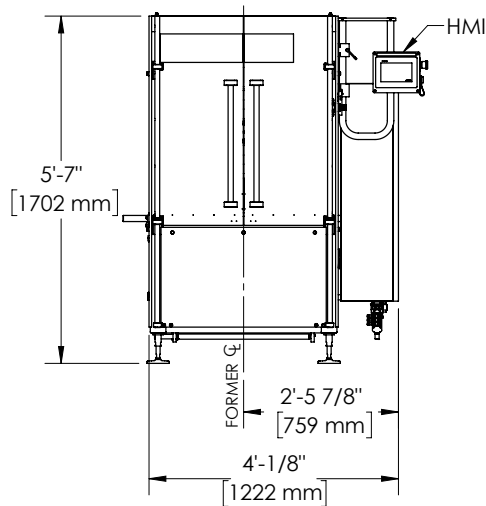

Side view

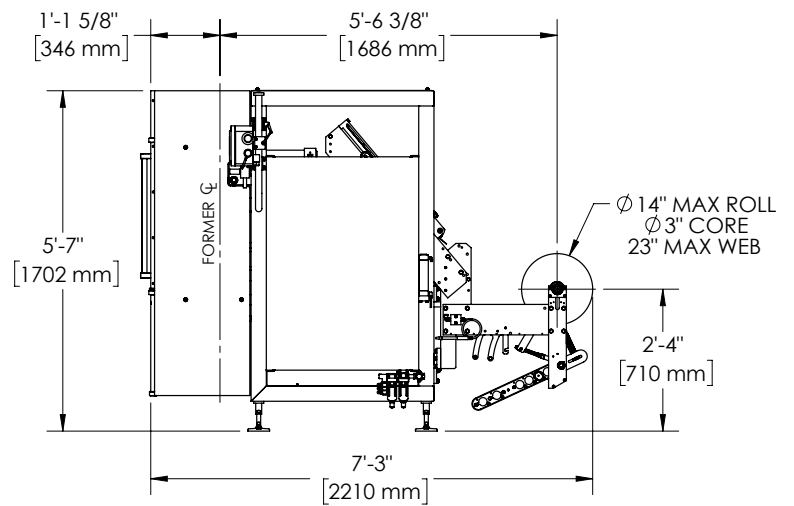

TYPICAL PRODUCT SPECIFICATIONS

Cycle Speed	Up to 140 BPM	
Electrical	230V, 30AMP, 1PH	
Air Pressure	80PSI, 8 to 20 CFM	
Bag Sizes	Width	Length
Minimum	2" (51 mm) pillow	3" (76 mm)*

*Longer bags possible with multi-pull feature.

Bag Sizes	Width	Length
Maximum	11" (280 mm)	15" (381 mm)*
Film Roll (Std)	14" diameter	
Film Roll Maximum	21" Diameter	
Film	Laminate or poly film sealing capability	
Filler	Compatible with all types	