

THIS DOCUMENT IS THE EXCLUSIVE PROPERTY OF INLINE FILLING SYSTEMS AND MAY NOT BE USED OR REPRODUCED, NOR ITS CONTENT OR PART THERE OF BE DISCLOSED TO OTHER BY ANY PERSON OR COMPANY WITHOUT THE WRITTEN CONSENT FROM INLINE FILLING SYSTEMS

CONVEYOR LINE
HEIGHT: 38 +/-2"

REVISION DESCRIPTION	DATE	INIT
----------------------	------	------

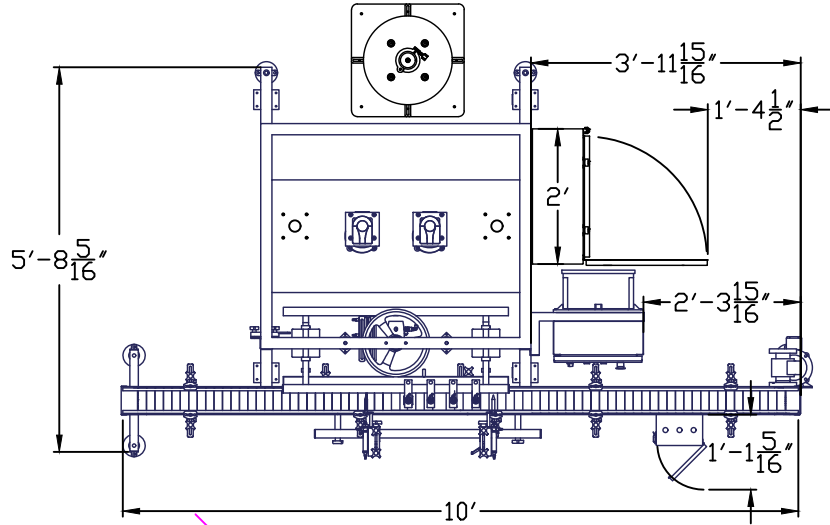

PRODUCT FLOW DIRECTION

FPD4 BASE MACHINE

- W/ FPD4 CONTROLS
- W/ FPD PUMP PERISTALTIC LARGE (x2)
- W/ FPERI NOZZLE 3/8 (x4)
- W/ FPERI FLUIDPATH
- W/ CONVEYOR 10 FT

Utilities Requirements:

- Electrical: 220VAC @ 25 AMPS
- Air: 7 CFM @ 80 PSI

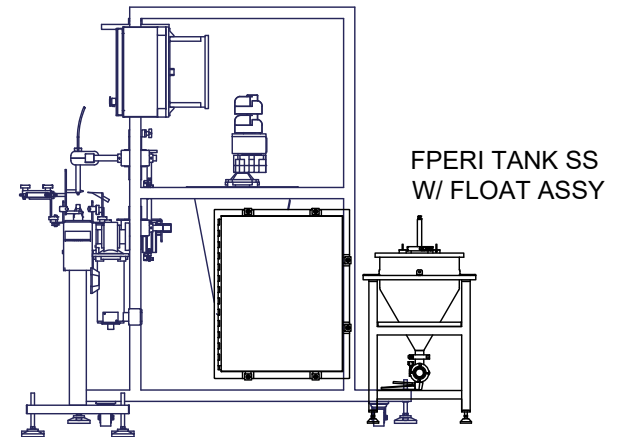
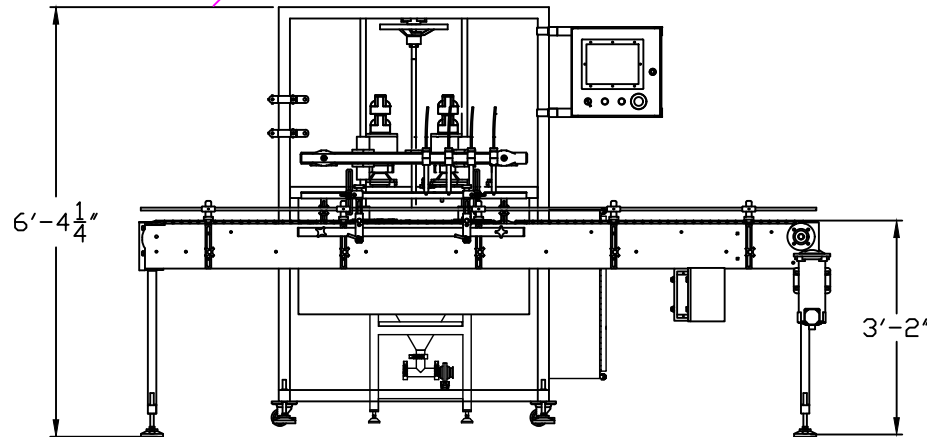

DRAWN BY:	DATE:	CHECKED BY:	COMPANY:
-----------	-------	-------------	----------

DOOR DIM : _____
ROOM DIM : _____
CEILING HT: _____

SALES ENGINEER	CONTACT #:
	125073



216 S. SEABOARD AVE. TEL: (941) 486-8800
VENICE, FLORIDA 34285 FAX: (941) 486-0077

ALL DIMENSIONS ARE IN FEET AND INCHES UNLESS OTHERWISE SPECIFIED.

APPROVAL DRAWING

- APPROVED
- APPROVED AS NOTED
- RESUBMIT
- SIGNED _____
- DATE _____

SHEET:
1 OF 1