

ACP (Automatic Case Positioner)

EMERALD
AUTOMATION

International Automation & Innovation



FEATURES

- ◆ Vertical & horizontal orientation
- ◆ Speeds up to 10 cases/min (12 with Servo)
- ◆ Ethernet communications
- ◆ Allen Bradley PLC Controls
- ◆ Air & vacuum saver system
- ◆ “Tool-less” Changeover

CONSTRUCTION

- ◆ Heavy-duty frame & manufactured parts
- ◆ Powder coating finish
- ◆ Low Pressure Wash-Down Option
- ◆ UL 508A Listed Enclosure
- ◆ Quick-disconnect field devices
- ◆ OSHA approved safety design

The **Automatic Case Positioner (ACP)** places the erected cases on a case packer mandrel to load the bags into the case. It is a fully automatic case positioner that is easily integrated with various case packers. The **ACP** is easy to operate and requires little adjustment.

Emerald Automation integrates a diverse yet practical approach to machinery design to provide rugged construction complemented with state-of-the-art technologies. Whether it's developing a machine to supply a new market, or rebuilding existing machines with new technology, we will work to provide our customers with solutions that meet their individual needs.

www.emeraldautomation.com

Emerald Automation

9228 W Clearwater Drive
Kennewick, WA 99336

Phone:

509.783.1369

Email:

sales@emeraldautomation.com

ACP

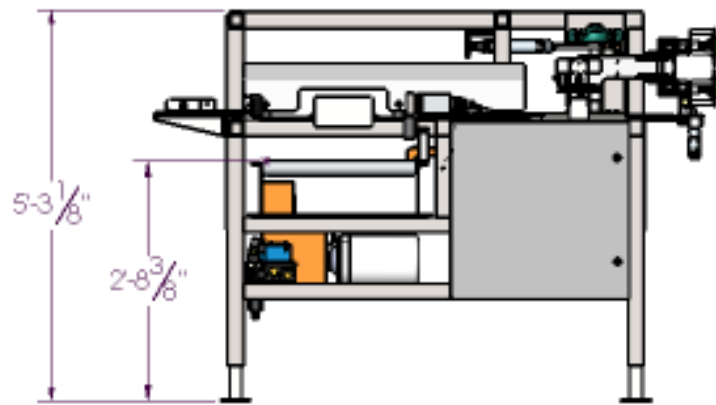
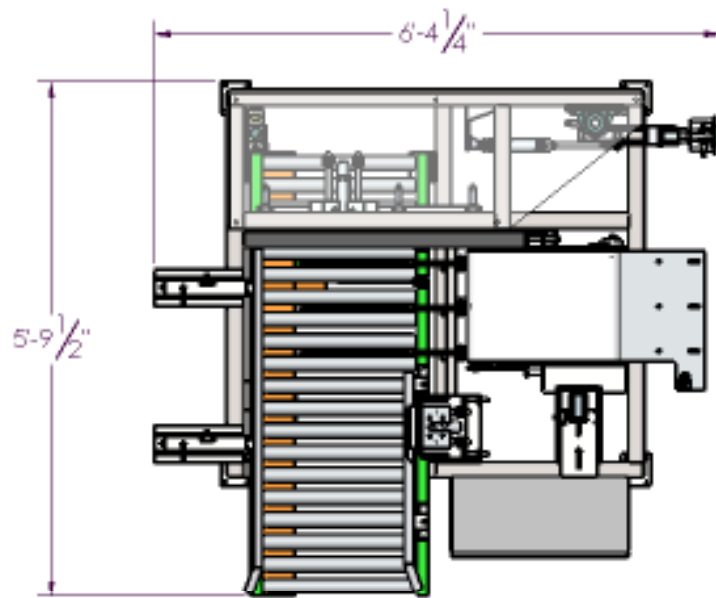

MISSION STATEMENT

Emerald Automation aspires to provide uncompromised products for today's most demanding packaging and automation for local, domestic and international manufacturers and processors. We have an unrivaled approach to turning concepts into innovative solutions - whether it is for an entire system, a single machine or just a bottleneck in the production line. We deliver exceptional results by using simple, efficient and cost effective methods that are client focused.

Emerald Automation

9228 W Clearwater Drive
Kennewick, WA 99336

Phone: 509.783.1369

Email: sales@emeraldautomation.com

EMERALD
AUTOMATION