

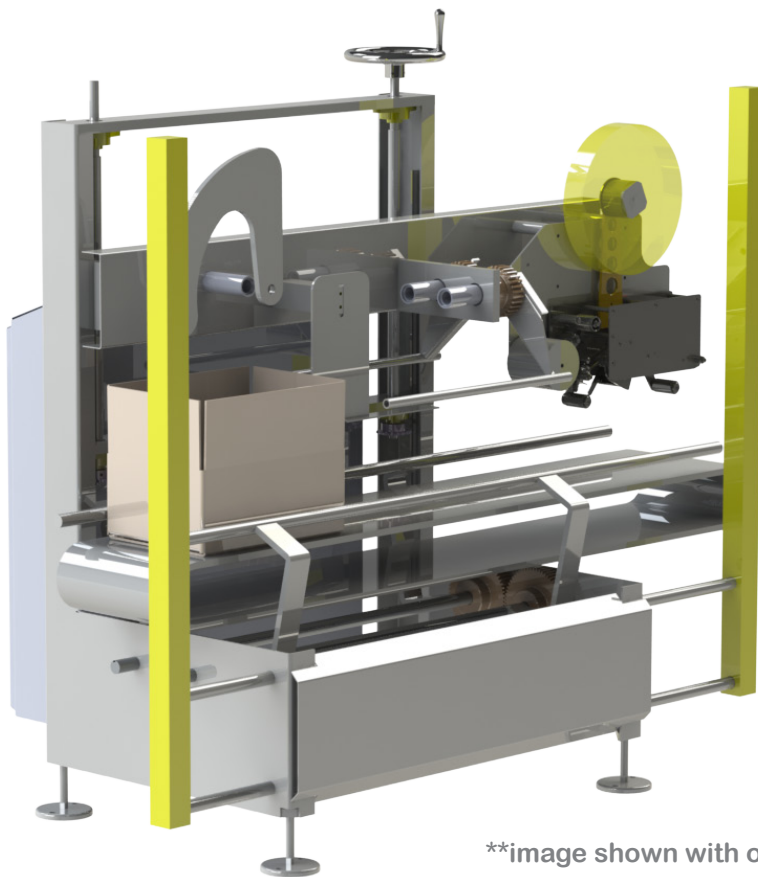

CASE SEALER

Our new “Clean” designs are not only suitable for wet environments but more importantly, were designed from the ground up to meet strict sanitary specifications. Our products are manufactured by a team of individuals specifically trained and familiar with food safety requirements including HACCP, AMI, 3A and others.

Our C16-T Case Sealer, compact in size, will automatically index in a loaded case, positively fold all four top flaps and seal with pressure sensitive tape at rates up to 16 cases per minute.



C16-T

**Compact Design Case Sealer
improves space...**

image shown with optional light curtain guarding

Also available with Hot Melt Glue Closure



C16-T Fully Automatic Case Sealer

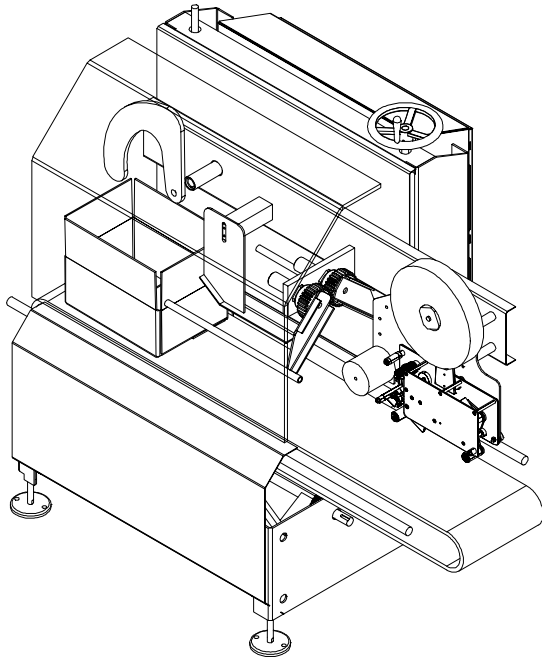

FEATURES

- Stainless Steel Open Form Frame
- Easy Clean wash down protection
- Centralized electrical and pneumatics
- Reduced wear points extend run times between maintenance intervals
- Self-evident adjustment points improve repeatability and speed of case size change overs
- Active 4 flap folding ensures positive closing and reduces jams created by overfilled cases
- Full perimeter guarding standard
- Light Curtain guarding optional
- Positive stop case indexing
- Bottom belt drive to accommodate low profile cases
- Tape Head is ready accessible for tape roll changes
- Magnum 2" Stainless Steel Tape Head

SPECIFICATIONS

| | |
|--------------------|--|
| Case Size Range | L10" W6" D4" (minimum) / L18" W12" D8" (maximum) |
| Machine Dimensions | L65" W36" D52" |
| Outfeed Height | D20" (minimum) / D24" (maximum) |
| Speed | Up to 16 case / min. |
| Controls | Beckhoff Automation |
| Pneumatics | Festo |
| Voltage | 208-240VAC, 3Ph |
| Frame | Stainless Steel Open Form |
| Sub-assemblies | Stainless Steel, UHMW Plastics and Anodized Aluminum |
| Fasteners | Stainless Steel |

