

Crate Erector **Stacker Palletiser**

🌿 This machine will reliably and economically erect Returnable Plastic Crates and palletize them ready for packing.

Capable of running the European, US and Australasian standard footprints in various heights at **up to 15 crates per minute**, the Oryx Crate Erector Stacker Palletiser is available with various options on the infeed and outfeed of the machine for manual or automatic handling of folded and erected Returnable Plastic Crates.

At Oryx, we make intelligent packaging machinery. Please visit our website at www.oryxautomation.com to see how we can help you.

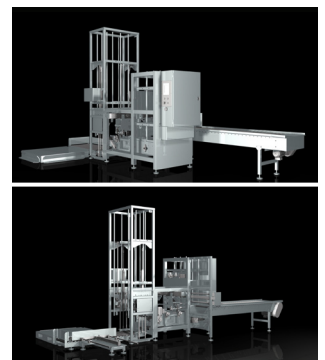

ORyx
AUTOMATION

Stacker Palletiser Features

Speed

Up to 15 crates per minute.

Small Footprint

for speed capability. Maximise your valuable floor space with this extremely compact design, relocatable by forklift.

Flexible layout options

that allow for the addition of crate infeed and pallet outfeed automation.

Automatic Operation

Allows for unattended operation of multiple heights, with **auto height-changeover** for most RPCs within a common range.

Fast Changeovers

Typically 10 minutes for range changes

Heavy Duty Construction

Stainless steel frame for durability and long lasting appeal.

Quiet Operation

Usually less than 80dB.

Advanced PLC System

with full monitoring of machine status and diagnostics. Internet access enables our engineers to provide **exceptional levels of remote support**.

Automatic Stack Infeed

Conveys stacks of unerected RPCs.

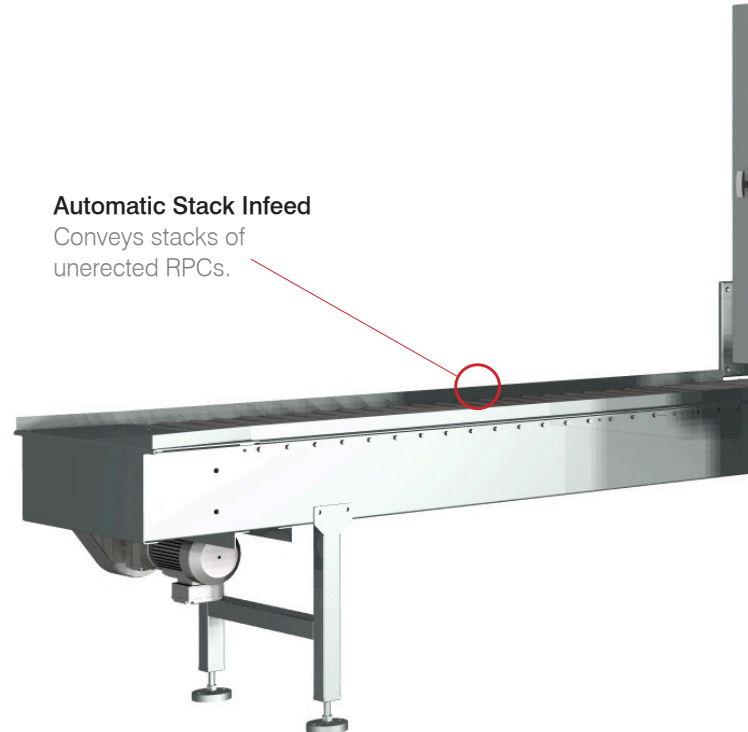

Available Options

Automatic Loading from Pallet

Stacks of folded crates on pallet are automatically loaded into the crate dispenser of the machine

Tag Label Inserter

Automatic Pallet Dispensing

Automatic Full Pallet Handling

RPC Types



➤ Foldable RPCs from the world's major pool operators. Custom designs available.

Touch Screen Display

for easy diagnostics of machine functions, simplifies tasks for operators and maintenance personnel.

Crate Stacker

Operator-set to various heights.

Heavy Duty Construction

Stainless Steel frame for durability.

Palletizing

Shown on the floor – can be automated with dispenser and conveyor.

RPC (Crate) Erector

See brochure.

Guarding to International Standards

Fully interlocked doors assist in access and visibility (not shown).

➤ “I associate FibreKing/
Oryx with excellent
service and superior
quality.”

Craig McNair, Maintenance
Engineer, Moraitis Group

➤ “RPCs have moved us into world’s best
practice. Choosing the right equipment has
maximized productivity around their use,
and been critical to our success.”

Darren Mitolo, Group Managing Director, Mitolo

The Oryx Difference

More Uptime

Oryx machines are designed and manufactured to withstand constant, rigorous use. Changeovers happen quickly and seamlessly; and we build in easy access for maintenance and upgrades. Our remote monitoring, PLC programming and service standards are such that some of the world's biggest companies choose Oryx and its parent company, Fibre King as their preferred supplier.

Lower Overall Cost of Use

Let's start with strategic design – we make a study of the end use and create a machine that does what it needs to most efficiently, using the best technology available. Oryx machines are tailored to your exact requirements, and the beauty is that if your requirements change, the equipment can usually be converted to suit. Less operator intervention is required on an Oryx machine; your products will be better protected in transit because of our superior quality packs; and all this is backed by faster maintenance and support, plus competitively priced spares.

'No Excuses' Service

We stand by our word, and move heaven and earth to make it happen.

“From the enquiry stage right through until final commissioning, Fibre King/Oryx were a fantastic company to deal with. The equipment went in without a hitch, and all their technicians conducted themselves in a courteous and professional manner. They knew the product they were supplying inside and out.”

Damien Rigato, Director, Rigato Farms



Oryx Automation/A Division of Fibre King Pty Ltd

71 Stevenson Street Suite 400 San Francisco California 94105

t. (415) 655 6887 f. (415) 655 6601

(Head Office)

9 Oasis Court, PO Box 3051 Clontarf DC Q 4019 Australia

t. +61 7 3889 4400 f. +61 7 3889 5255

e. sales@oryxautomation.com w. www.oryxautomation.com