

CONTRACT PACKAGER SERIES

CP2000 Contract Packager Front/Back and Round Product Labeling

- Extra heavy-duty system framework
- Easy, rapid changeover
- Product metering
- Servo synchronous overhead hold down
- Servo synchronous product positioning
- Two SL2000 stepper-driven label applicators
- NEMA 12 control enclosure with multilevel menu



CP1000 Contract Packager Front/Back and Round Product Labeling

- Extra heavy-duty system framework
- Easy, rapid changeover
- Product metering
- Servo synchronous overhead hold down
- Servo synchronous product positioning
- Two SL1500 stepper-driven label applicators
- NEMA 12 control enclosure with multilevel menu



UNIVERSAL
labeling systems

Engineering
labeling solutions.

SPECIFICATIONS

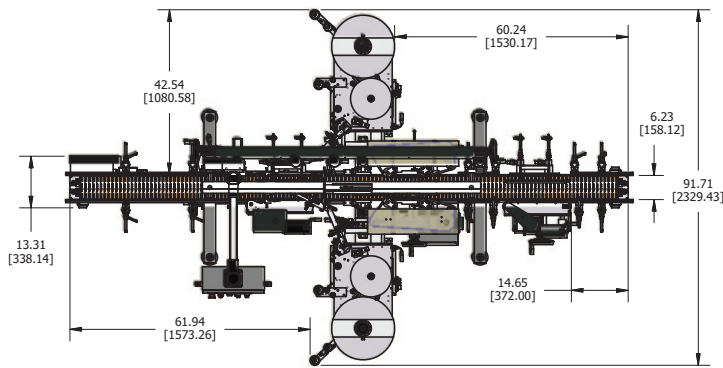

← FLOW

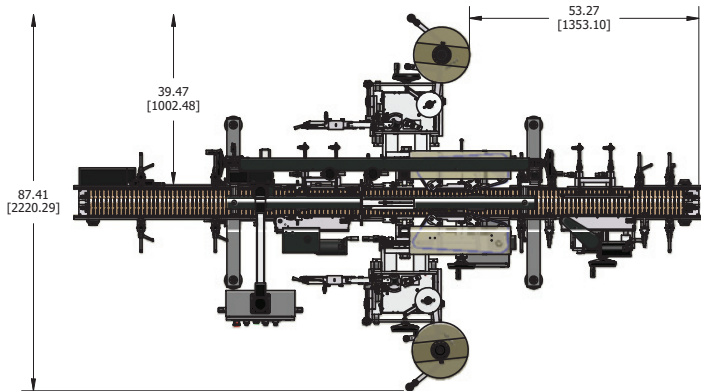
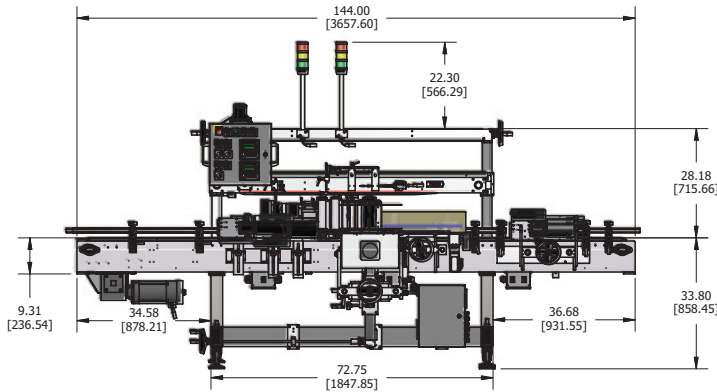

← FLOW

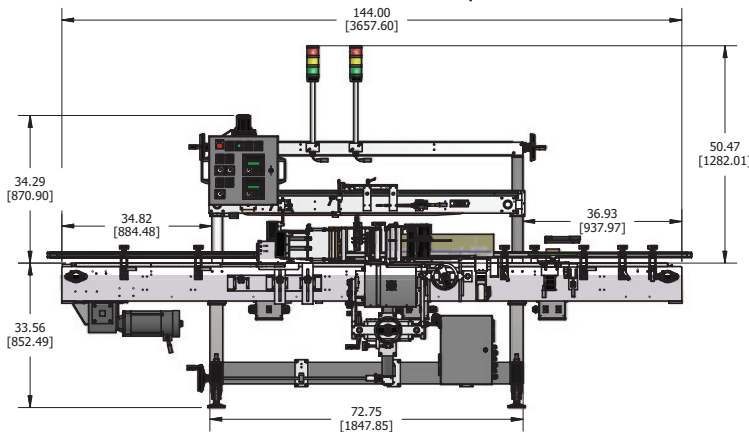

CP2000

- 92"W x 144"L x 62"H
(Conveyor height to customer specifications with 4" total variance)
- Label dispense speed: up to 3000" per minute
- Label roll capacity: 16" Ø
- Web width: up to 6.375"
- Job save capacity: 99
- Electric: 120 VAC +/-10%
- Shipping weight: approx 1700 lbs.

Options

- Wide label capacity to 8.125"
- Hot stamp imprinter
- Feed and accumulating tables
- Low label detection

CP1000

- 88"W x 144"L x 62"H
(Conveyor height to customer specifications with 4" total variance)
- Label dispense speed: 1500" per minute
- Label roll capacity: 12" Ø
- Web width: up to 6.375"
- Job save capacity: 99
- Electric: 120 VAC +/-10%
- Shipping weight: approx 1500 lbs.

Options

- Wide label capacity to 8.125"
- Hot stamp imprinter
- Feed and accumulating tables
- Low label detection