



Thermo Scientific NextGuard X-ray Inspection System

- Detects a wide variety of foreign objects
- Simple to install, operate and service
- Flexible software to verify product integrity
- Two aperture sizes available

cost-effective yet sensitive

contaminant detection and product
quality inspection for packaged
products

The Thermo Scientific™ NextGuard™ X-ray system is designed to make moving from metal detection to X-ray detection easy, fast and inexpensive. It is ideal for finding dense or sharp objects in a wide variety of products as well as detecting errors like over/under fill or missing, misplaced, cracked or incorrectly formed products.

Thermo
SCIENTIFIC

Thermo Scientific NextGuard

X-ray inspection for a wide variety of food products

The Thermo Scientific™ NextGuard™ detection system enables compliance with worldwide HACCP and retailer food safety requirements. It is an easy to use, cost effective, thoughtfully designed system that eliminates the barriers associated with moving from metal detection to X-ray detection.



Innovative X-ray Design Assures 100% Detection of Any Product

Most X-ray detection systems project the X-ray beam from the top down in a narrow beam to a linear detector. This makes using the X-ray image for product inspections easier, but also means as the product being inspected gets taller it must get narrower to always fit in the beam. With NextGuard we wanted to make it simple for users, so we project a wide X-ray beam from the bottom up to a non-linear detector that assures everything passing through the inspection tunnel is completely inspected. Any differences in X-ray signal across the arch-shaped detector are automatically calibrated out when you set-up your product. So no matter where the product passes through the beam, you always get the best detection possible! This architecture has the added benefit of limiting the height of the total machine and providing for optimum cooling, thus extending the life of the source.

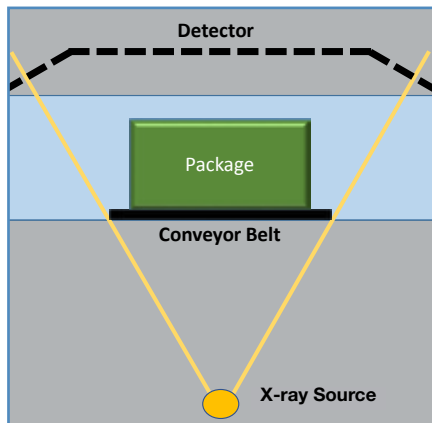

NextGuard X-ray Source and Detector Arrangement



Through the Thermo Scientific Product Assurance Services & Solutions (PASS) program, we can thoroughly test every suspected product for contaminants so that you can continue producing products that your consumers rely on! Learn more at www.thermoscientific.com/PASS.

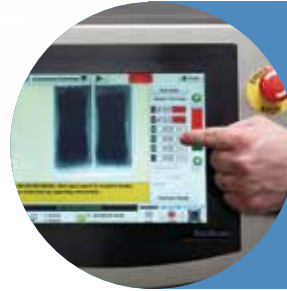

Touchscreen

Protected, large touchscreen for washdown and durability. Adjust image function for on-the-fly detection adjustment while the system is inspecting.

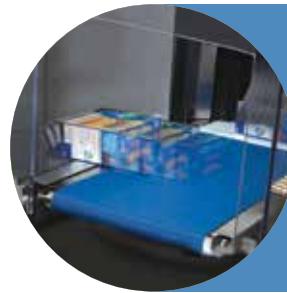

Rejection Systems

Configurable rejection systems customized for any application. Variable speed controlled by the NextGuard. Dual rejection to separate foreign objects from quality defects.



QA Check Function

Unique, configurable software feature allows definition of up to three audit types. Prompts the operator to run the audit and saves statistics/images from the process separately from production data.

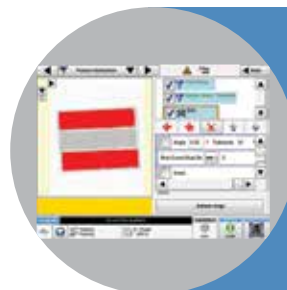

Product Verification Software

Flexible inspection software to find product quality defects such as missing pieces, incorrect product sizes and cracks all without having to create customized software specific to your application.

X-ray inspection system

Features & Benefits

- Compact size makes installation and use easy
- Unique non-linear detector eliminates inspection blind spots
- Removable conveyor makes directional change and maintenance simple
- Software based on popular, intuitive VersaWeigh user interface
- Modular design for high reliability and quick diagnosis and repair
- Source and detector lifetime indicators to minimize expensive downtime
- Built-in remote monitoring for quick problem determination
- Field upgradable X-ray sources and detectors

Options to Customize Your Systems

- Complete rejection systems or rejection mechanisms for use on your downstream conveyor
- High resolution detectors and multiple X-ray sources
- Product Verification and Mass Estimation software
- Stainless steel air conditioner for washdown environments
- Alarm horn; Teflon coated lightweight no-lead curtains, casters, guiderails
- Radiation safety meters
- Full Marks and Spencer COP compliance
- Spare parts kits
- Configurations for lightweight or unwrapped products



Certified around the world

Safety is assured with an LED light stack, multiple e-stops, X-ray key switch and safety interlocks on all doors and covers.



USB and Ethernet ports

Standard watertight connections are available for data input/output and remote connection for help and troubleshooting.



Radiation shielding curtains (with cover removed)

Food safe, no-lead curtains that are easy to adjust and maintain.



Modular conveyor

Transport system is completely removable in minutes for thorough cleaning, belt change and maintenance/repair. Conveyor direction can be changed in the field by service technicians in less than one hour.



Modular feet, extensions and frames to fit any line height needed.

Thermo Scientific NextGuard X-ray Detection System

Note: NextGuard is available with two aperture sizes, the C330 and C500. See the diagram below to determine the correct model for your application.

Application and X-ray Specifications	
X-ray Power	C330: 100 W (80kV/1.25mA) or 160W (80kV/2mA), C500: 160W (80kV/2mA) or 200W (90kV, 2.2mA)
X-ray Detector	Unique design with no inspection blind spots, 0.8mm or optional 0.4mm pixel size (Note 0.4mm only available on the C330)
Scan Rate	Up to 1667 lines per second
Typical Sensitivity	>= 1mm diameter for Fe, non-Fe, SS, >=3mm for other dense contaminants such as glass or stone (always verify application performance via a product test)
Detection Algorithms Available	Simple threshold, gradient, morphologies and contaminant area measure
Maximum Product Width and Height	C330: 330mm X 185mm (13.0in X 7.3in), C500: 500mm X 250mm (19.7in X 9.8in)
Inspection Algorithms Available	Image processing/thresholding/blob analysis, grayscale profiling and mass estimation
Belt Speed	C330: 10-80m/min (33-262ft/min), C500: 5-50m/min (16-164ft/min)
Maximum Product Weight on the Conveyor	C330: 6kg (13lbs), C500: 11kg (25lbs)
Conveyor Heights	800 mm (31.5 in), 900 mm (35.4 in), 1000 mm (39.4 in), 1100 mm (43.3 in) - specify at order time
Conveyor Length	C330: 1m (3.3ft), C500: 1.2m (3.9ft)
Belt Material	USDA/FDA approved urethane
Roller Diameter	C330: 34mm (1.3in), C500: 49mm (1.9in)
Security/Safety Features	X-ray power key, four level password system, emergency X-ray/conveyor stop button, lead/lead-free curtains, failsafe LED X-ray imminent and on indication light
Human Machine Interface (HMI)	Windows® 7, touchscreen, 307 mm (12.1 in) diagonal
Language Interfaces Available	English, Spanish, French, Italian, German, Chinese, Russian, Polish, Czech and Portuguese. Contact factory for additional languages.
Data File Export/Import	Images, event logs, statistics, audit reports, product files and machine parameters
Remote Access	Teamviewer built-in
External Rejecter Options	Integrated variable speed conveyors. Air blast or pusher. Lockable reject bin and reject/bin full photo sensors. Dual rejectors possible.
Environment, Electrical and Operational Specifications	
Operating Temperature	5°C to 30°C (41°F to 86°F) with cooling fan or 5°C to 40°C (41°F to 104°F) with air conditioner (Note C500 only available with air conditioner)
Relative Humidity	20% to 90% non-condensing
Electrical Supply	195 VAC to 250 VAC, 50/60 Hz, autosensing, single phase, 10 amps.
Digital Outputs/Allocation	Four outputs, 24 VDC 0.5 A, assignable function
Digital Inputs/Allocation	Four inputs, 24VDC 25 mA, NPN/PNP (jumper selectable), assignable function
USB Port	Watertight USB 2.0 standard
Ethernet Port	Watertight Ethernet port standard
Machine Weight	C330: 320kg (700lbs), C500: 335kg (740lbs)
Conformance Tests and Certifications	
Radiation Conformance	FDA CFR 21 part 1020.40, RED act (Canada), IRR99 (UK), NCF 74-100 (France), UNE 73-302 (Spain), GB18871-2002 (China) and others. Note UK, Canada and Spain require optional extended guarding and France requires optional extended shielding.
Export and Safety	CE, IEC 61010-1
IP Washdown Conformance	IP65 with air conditioner, IP54 with cooling fans. Full stainless steel type 304 construction.
Manufacturing Quality	ISO9001 certified facility

Thermo Scientific NextGuard Apertures/Inspectable Area

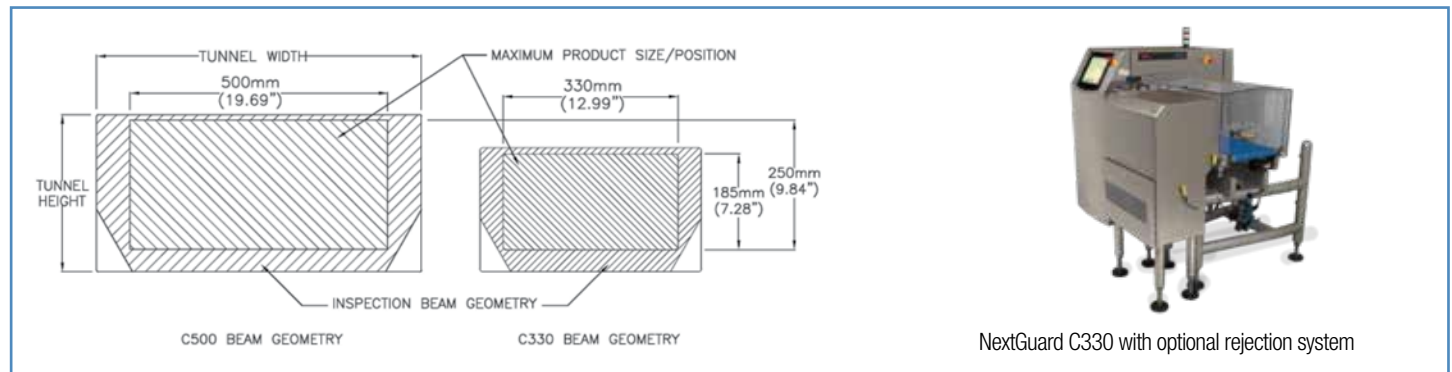

www.thermofisher.com/nextguard

© 2016 Thermo Fisher Scientific Inc. All rights reserved. All trademarks are the property of Thermo Fisher Scientific Inc. and its subsidiaries. Specifications, terms and pricing are subject to change. Not all products are available in all countries. Please consult your local sales representative for details.

US and Canada 800 227 8891
Australia/NZ +1300 735 292
Mexico +52 55 5639 2184
Argentina +54 11 4334 3827
Chile +56 22 2378 5080

India +91 20 6626 7000
Italy +39 0 5217 8861
France +33 (0) 16 092 4800
Germany +49 (0) 20 882 4930
Spain +34 (0) 91 484 5965

UK +44 (0) 17 8882 0300
Netherlands +31 (0) 76 579 5555
South Africa +27 11 776 0000
China 800 810 5118
Brazil +55 11 2730 3261
Southeast Asia +65 6499 9981

Thermo
SCIENTIFIC

A Thermo Fisher Scientific Brand

Email: sales.packaging.us@thermofisher.com

Literature Code CAD.PI03.0316